



INSTALLATION INSTRUCTIONS FOR PART 95-8904B

APPLICATIONS

Subaru Legacy 2009-up Subaru Outback 2009-up

(non nav models)

95-8904B

KIT FEATURES

- DDIN radio provision
- ISO stacked provision
- Painted scratch resistant matte black

*Note: Minor sub-dash modifications required.
Part # 95-8903B does not require these modifications.*



KIT COMPONENTS

- A) DDIN Trim Plate
- B) DDIN Brackets

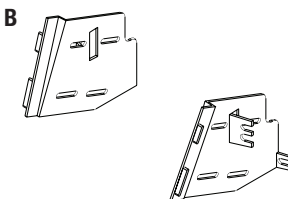
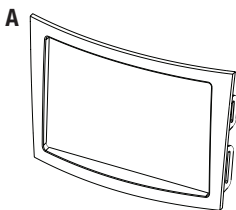

WIRING & ANTENNA CONNECTIONS (Sold Separately)

- Wiring Harness:
- 70-8901 Subaru harness 1990-up
 - 70-7552 Nissan harness 2007-up

- Antenna Adapter:
- 40-SB10 Subaru antenna adapter 2005-up

TOOLS REQUIRED

- Panel Removal Tool • Phillips Screwdriver • Small Flat Blade Screwdriver • Utility Knife • Cutting Tool

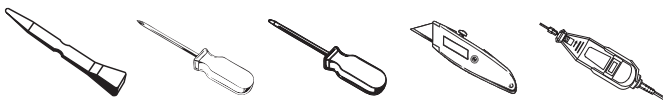

METRA. THE WORLD'S BEST KITS.™



1-800-221-0932



metraonline.com

© COPYRIGHT 2004-2011 METRA ELECTRONICS CORPORATION



95-8904B

Table of Contents

Dash Disassembly

- Subaru Legacy 2009-up.....3
- Subaru Outback 2009-up.....3

Kit Assembly

- DDIN/stacked ISO head unit provision 4

Caution

Metra recommends disconnecting the negative battery terminal before beginning any installation. All accessories, switches, and especially air bag indicator lights must be plugged in before reconnecting the battery or cycling the ignition.

****NOTE: Refer also to the instructions included with the aftermarket radio.***



KNOWLEDGE IS POWER

Enhance your installation and fabrication skills by enrolling in the most recognized and respected mobile electronics school in our industry. Log onto www.installerinstitute.com or call 800-354-6782 for more information and take steps toward a better tomorrow.



Metra recommends MECP certified technicians

Dash Disassembly

1. Unclip and remove the radio trim panel including the a/c vents. (Figure A)
2. Remove (4) Phillips screws securing the factory radio.

Continue to kit assembly

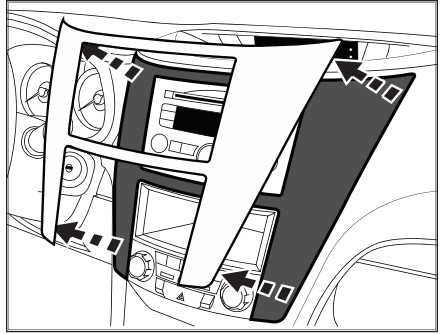

(Figure A)



Kit Assembly 95-8904B

DDIN/stacked ISO head unit provision

1. Locate the factory wiring harness in the dash. Metra recommends using the proper mating adapter from Metra or AXXESS. Re-connect the negative battery terminal and test the unit for proper operation.
2. Attach the Double DIN brackets to the Double DIN trim plate. (Figure A)
3. Slide the Double DIN head unit or stacked ISO head units into the bracket/radio housing assembly and secure the Double DIN head unit or stacked ISO head units to the assembly using the screws supplied with the radio. (Figure B)
4. Using an air saw, hacksaw, or similar cutting tool, cut to the inside of the radio's lower mounting holes, through the plastic and metal bracket. ***(Cut on the inside of each hole as close to the hole as you can get. If cut properly you may re-use two bottom factory screws, if not use self tapping screws on the bottom.)*** (Figure C)
4. Reassemble dash in reverse order of disassembly.

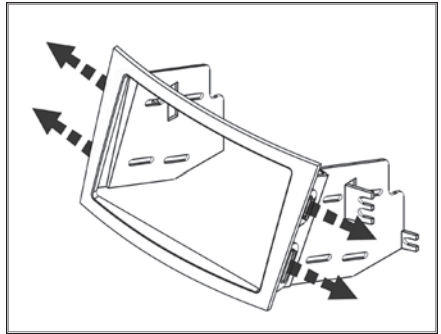

(Figure A)

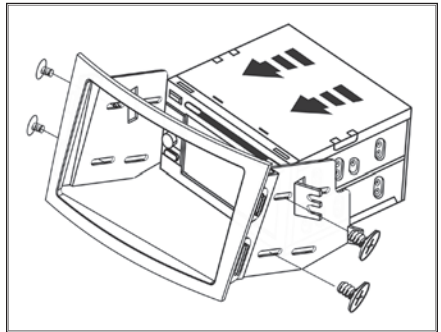

(Figure B)

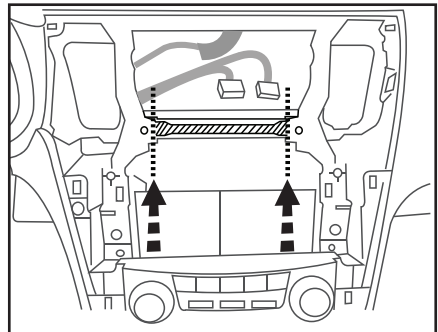

(Figure C)



INSTALLATION INSTRUCTIONS FOR PART 95-8904B

REV. 6/02/11

METRA. THE WORLD'S BEST KITS.™



1-800-221-0932



metraonline.com

© COPYRIGHT 2004-2011 METRA ELECTRONICS CORPORATION