

# PN2 STORM

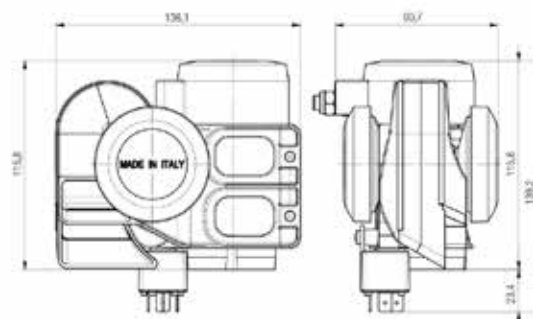

## TECHNICAL DRAWING



## DESCRIPTION

Powerful electropneumatic bitonal horn, harmoniously tuned. Compact dimensions. Easy to install, without connecting pipes! This horn allows you to be heard at the moment of impending danger on the road. High reliability engine! Ideal for bikes (suitable for surface mounting), cars, SUV, RV, etc. ...

## PHOTO DETAILS



## TECHNICAL SPECIFICATIONS

		PN2 Storm
Nominal Voltage	V	12 (24)
Current consumption (at 24V)	A	± 18A (9A)
Sound Level at 2 m	dB(A)	110
Fundamental Frequency	Hz	670 (high) and 530 (low) Hz ±5%
Sound		Harmonized twin tone
Reliability		50.000 on/off cycles
Operating temperature	°C	-20 +80
Approved to ECE and ECC directives		Yes
Electromagnetic compatibility		Yes
Main Use		bikes, cars, SUVs, RVs...

## PACKAGE SIZES

		PN Storm
Package size	mm	160 x 91 x 125 (h)
Product weight including package	kg	0,740
Outer package size	mm	315 x 290x 390 (h)
Quantity per outer package	nr	18
Outer package weight including products	kg	14,7

## PACKAGING

