

# TW80 ELECTROMAGNETIC HORN

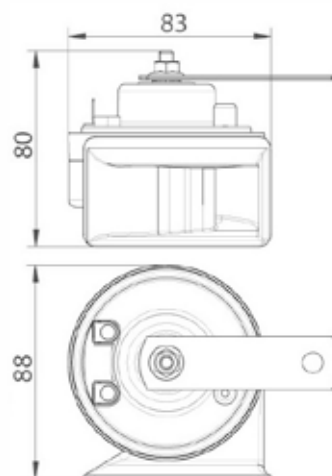

## TECHNICAL DRAWING



## DESCRIPTION

Electromagnetic horn with an ABS coil. Its light weight easily combines with considerable output and low energy consumption. The bleeder it is equipped with for pressure compensation is a guarantee of higher durability and reliability. The standard iridescent white trivalent zinc-coating treatment guarantees excellent resistance to salt spray tests.

## PHOTO DETAILS



## TECHNICAL SPECIFICATIONS

		TW80-H	TW80-L	TW80/2
Nominal Voltage	V	12 (24)		
Power Supply		unipolar - bipolar		
Absorbed current at 13V (26V)	A	4(2,5)	4(2,5)	8(5)
Sound Level at 2 m	dB(A)	109	109	112
Fundamental Frequency	Hz	500 ± 5%	420 ± 5%	(500 - 420) ± 5%
Type of sound		high	low	high and low
Weight including leaf spring brackets	kg	0,220	0,220	0,440
Reliability		50000 cycles (1" on - 4" off)		
Protective coating for metallic parts		Cr3 iridescent white zinc-coating		
Operating Temperature	°C	-20 +80		
Type-approvals		70/388 EEC- R.28 ECE/ONU - 93/30 EEC		
RoHS regulations		complied with		
Main use		motorcycles, cars, heavy-weight vehicles		

## PACKAGE SIZES

		SINGLE BOX	DOUBLE BOX
Package size	mm	115x115x80(h)	200x110x80(h)
Product weight including package	kg	0,240	0,50
Outer package size	mm	570x420x270(h)	570x420x270(h)
Quantity per outer package	nr	50	30
Outer package weight including products	kg	12	15
Outer package volume	m3	0,065	0,065

## PACKAGING

